



ANTI-VANDAL DOME CAMERA

SCC-C9302(F)

User's Manual

Guide de l'utilisateur

Guía del Usuario

ユーザーズ・マニュアル

- E
- F
- Es
- J



Important Safety Instructions

1. Read these instructions.
2. Keep these instructions.
3. Heed all warnings.
4. Follow all instructions.
5. Do not use this apparatus near water.
6. Clean only with dry cloth.
7. Do not block any ventilation openings, Install in accordance with the manufacturer's instructions.
8. Do not install near any heat sources such as radiators, heat registers, or other apparatus (including amplifiers) that produce heat.
9. Do not defeat the safety purpose of the polarized or grounding- type plug. A polarized plug has two blades with one wider than the other. A grounding type plug has two blades and a third grounding prong. The wide blade or the third prong are provided for your safety. If the provided plug does not fit into your outlet, consult an electrician for replacement of the obsolete outlet.
10. Protect the power cord from being walked on or pinched particularly at plugs, convenience receptacles, and the point where they exit from the apparatus.
11. Only use attachments/accessories specified by the manufacturer.
12. Use only with cart, stand, tripod, bracket, or table specified by the manufacturer, or sold with the apparatus.



13. Unplug this apparatus. When a cart is used, use caution when moving the cart/apparatus combination to avoid injury from tip-over.
14. Refer all servicing to qualified service personnel. Servicing is required when the apparatus has been damaged in any way, such as power-supply cord or plug is damaged, liquid has been spilled or objects have fallen into the apparatus the apparatus has been exposed to rain or moisture, does not operate normally, or has been dropped.

Safety Precautions

The purpose of safety precautions is to prevent accidental injury or property damage. Always observe all safety precautions.

❖ The precautions are divided into "Warnings" and "Cautions" as distinguished below:

<p>Warning Ignoring this precaution may result in death or serious injury.</p>	<p>Caution Ignoring this precaution may result in injury or damage to property.</p>

Warnings

1. Be sure to use only the standard adapter which is specified in the specification sheet.
Using any other adapter could cause fire, electrical shock, or damage to the product.
2. Check the external connection terminals first before connecting the power source and signal wires.
Connect the alarm signal wires to the alarm terminals. Connect the DC12V power adapter to the SCC-C9302 power input, making sure that the correct polarity is observed.
Connect the DC12V or AC24V power adapter to the SCC-C9302 power input.
3. Do not connect multiple cameras to a single adapter. (Exceeding the capacity may cause abnormal heat generation or fire.)
4. Securely plug the power cord into the power receptacle.
(A loose connection may result in fire.)
5. When mounting the camera on a wall or ceiling, fasten it safely and securely.
(A falling camera may cause personal injury.)

Safety Precautions

6. Do not place conductive objects (e.g., screwdrivers, coins, and metal things) or containers filled with water on top of the camera.
(Serious injury may result from fire, electrical shock, or falling objects.)
7. Do not install the unit in humid, dusty, or sooty locations.
(Doing so may cause fire or electrical shock.)
8. If any unusual smells or smoke come from the unit, stop using the product. In such case, immediately disconnect the power source and contact the service center. (Continued use in such a condition may cause fire or electrical shock.)
9. If this product fails to operate normally, contact the store of purchase or your nearest service center. Never disassemble or modify this product in any way. (Problems caused by unauthorized user disassembly or repairs are not covered by your warranty.)
10. When cleaning, do not spray water directly onto parts of the product.
(Doing so may cause fire or electrical shock.) Gently wipe the surface with a dry cloth. Never use detergents or chemical cleaners on the product, as this may result in discoloration of surface or cause damage to the finish.



Cautions

1. Do not drop objects on the product or apply strong shock to it. Keep away from a location subject to excessive vibration or magnetic interference.
2. Do not install in a location subject to high temperature, low temperature, or high humidity.
(Doing so may cause fire or electrical shock.)
3. Avoid a location which is exposed to direct sunlight, or near heat sources such as heaters or radiators.
(Neglecting to do so may result in a risk of fire.)
4. If you want to relocate the already installed product, be sure to turn off the power before moving or reinstalling it.
5. Install in a well-ventilated location.
6. Remove the power plug from the outlet when there is a lightning storm. (Neglecting to do so may cause fire or damage to the product.)

FCC Statement

This device complies with Part 15 of the FCC Rules. Operation is subject to the following two conditions:

- (1) This device may not cause harmful interference, and
- (2) This device must accept any interference received, including interference that may cause undesired operation.

Note:

This equipment has been tested and found to comply with the limits for Class B digital devices, pursuant to Part 15 of the FCC rules. These limits are designed to provide reasonable protection against harmful interference in a residential installation. This equipment generates, uses and can radiate radio frequency energy and, if not installed and used in accordance with the instructions, may cause harmful interference to radio communications. However, there is no guarantee that interference will not occur in a particular installation. If this equipment does cause harmful interference to radio or television reception, which can be determined by turning the equipment off and on, the user is encouraged to try to correct the interference by one or more of the following measures:

- Reorient or relocate the receiving antenna
- Increase the separation between the equipment and receiver
- Connect the equipment into an outlet on a circuit different from that to which the receiver is connected
- Consult the dealer or an experienced radio/TV technician for help Use of shielded cable is required to comply with Class B limits in Subpart B of Part 15 of the FCC rules.

Do not make any changes or modifications to the equipment unless otherwise specified in the manual. If such changes or modifications should be made, you could be required to stop operation of the equipment.

Table of Contents

Chapter 1	Overview	7
	Introduction	8
	Part Names and Functions	9
Chapter 2	Installing the Camera	11
	Before Installation	12
	Preparing Cables	16
	Installing the Camera	17
	Connecting Cables and Checking Operations	24
Chapter 3	Setup Menu Overview	26
	Structure of the Setup Menu	27
	CAMERA MENU Organization	28
	CAMERA ID	28
	IRIS	28
	SHUTTER	33
	AGC/MOTION	34
	WHITE BAL	35
	FOCUS MODE	36
	ALARM SET	37
	COLOR/BW	39
	PRIVACY	42
	SPECIAL	44
	PRESET	48
	EXIT	49
	External Connector Pin Specifications	52
	Product Specifications	53

Chapter 1 Overview

This chapter briefly introduces the Camera and describes its key features, part names and functions.



Introduction

The Anti-Vandal Dome Camera is a dome-typed surveillance device that offers the best features of surveillance for banks, retail stores, commercial buildings, industrial settings, and etc. It is designed to withstand intentional or accidental impact or vandalism, and is waterproof, dustproof, and shockproof.

The Camera is an advanced surveillance device that enables a maximum of 120x zoom surveillance with its 12x zoom lens and digital zoom IC.

The Camera is a multifunction surveillance device that is equipped with all of the key features of the existing surveillance cameras: the Low-Light Surveillance function that enables shooting moving objects under extremely low illumination, the White Balance function that provides accurate color rendition under any light source, the BLC function that enables effective back light compensation even at locations with bright incident light, and the Auto Focus function that automatically tracks and focuses on the moving subject.

Part Names and Functions

Front View



Rear View



SCC-C9302

SCC-C9302F

Part Names and Functions

E

❶ Camera Operation Switches (Setup Switches)



The functions of the camera operation switches change depending on whether the Camera is currently in the usual operation mode (i.e., the setup menu is not showing on the screen) or the setup menu mode.

→ In the usual operation mode

- [UP/DOWN] Directional keys: The [UP] key is used as the ZOOM TELE switch, and the [DOWN] key is used as the ZOOM WIDE switch.

- [LEFT/RIGHT] Directional keys: The [LEFT] key is used as the FOCUS NEAR switch, and the [RIGHT] key used as the FOCUS FAR switch.

- [ENTER] key: This key is used to go into the setup menu.

→ In the setup menu mode

- [UP/DOWN] Directional keys: These keys are used to move the cursor up and down.

- [LEFT/RIGHT] Directional keys: These keys are used to move the cursor left and right, or to sequentially view the values that can be assigned in each setup menu.

- [ENTER] key: This key is used to select a setup menu with a submenu in order to open the submenu, and to accept the current value.

❷ Power Input Connector and Video Output Connector (4-Pin)

These connectors are used to connect the power adapter cable and video input cable.

❸ RS485 Connector and Alarm Output Connector (4-Pin)

These connectors are used to connect an RS485 remote control cable and a cable used for transmitting the ALARM signal at the time of the MOTION DET mode.

Chapter 2 Installing the Camera

E

This chapter explains what to check before installing the Camera, how to choose an installation site, and what precautions should be taken during installation. Now, let's install the Camera and connect cables.



Before Installation

Checking the Contents of the Package

Be sure to check that the following items are included in the package.

E



Anti-Vandal Dome Camera

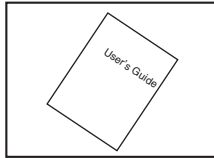

User's Guide

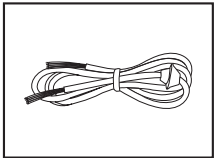

ALARM & RS485 Cable

Image	Item Name	Standard	Quantity	Use
	PLASTIC ANCHOR	HUD 5	4EA	Insert into the SCREW hole of the installation location (to strengthen the installation).
	ASSY SCREW MACHINE	BH M5 X L6... WHITE+0 RING	SCC-C9302:8EA SCC-C9302F:4EA	Use to block holes on the ceiling assembly of the CASE when installing the PIPE,WALL MOUNT and other items.
	ASSY SCREW TAPPING	TH M4 X L30 BLK+0 RING	4EA	Use for installation on the ceiling or wall.
	LWRENCH	TROX T-20	1EA	For COVER-DOME assembly.
	TEMPLATE		1EA	GUIDE for installation.

E

Before Installation

Before Installation

- Make sure the installation location can support over 5 times (approx.5.5 kg)the total weight of the ANTI VANDAL DOME CAMERA (SCC-C9302).
- Be careful not to let the cable be jammed in inappropriate places or to let the insulation covering of the cable peel off during installation. This may result in malfunction or a fire hazard.
- Items may fall and may cause hazards while installing the product. Therefore ensure that no-one is beneath the installation location. Move valuables to a safe place before installation.

Installation Example

- Able to install on ceilings.
- Directly install on a PIPE coming down from the ceiling.
- Directly install on walls.
- Directly install on a PIPE coming out from a wall.
- Install on walls, corners in buildings, columns and other locations using the WALL MOUNT ADAPTOR (SADT -102WM), COVER MOUNT ADAPTOR (SADT-110CM)and POLE MOUNT ADAPTOR (SADT-100PM).
(The above ADAPTOR types are sold separately.)

Description of Installation HOLES

- A : Use when directly installing on the ceiling or a wall.
 - Waterproofed only when the SCREW -MACHINE (M5 X L6...)is closed up when not in use.
- B : Use when directly installing on the JUNCTION BOX
 - SCC-C9302 can be assembled into a 4 1/8" DIAMETER ROUND TYPE JUNCTION BOX.
 - SCC-C9302F is assembled outside of the 4 1/8" DIAMETER ROUND TYPE EXTENSION BOX, and then must be covered with the GASKET and COVER.
(JUNCTION BOX, GASKET and COVER are sold separately.)
- C : Use when installing the WALL MOUNT ADAPTOR (SADT - 102WM)
 - Waterproofed only when the SCREW -MACHINE (M5 X L6...)is closed up when not in use.

SCC-C9302 bottom

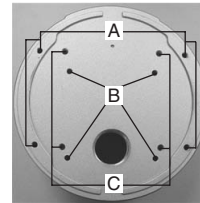

SCC-C9302F bottom

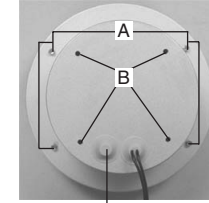

To additionally connect the ALARM CABLE, remove the rubber stopper, pass the cable through the hole and connect.
- The rubber stopper attached to the ALARM CABLE must be properly set onto the CASE to make it waterproof.

Preparing Cables

The following cables are required to install and use the Camera.

Power Adapter Cable

The power adapter that plugs into the Camera's power input receptacle has the rated voltage of DC 12V 600mA or AC 24V 300mA.

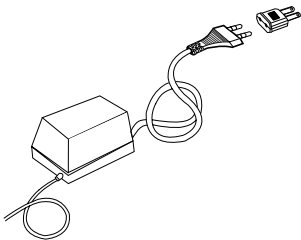

Video Cable

The cable that connects the video output terminal of the Camera to the monitor is a BNC cable.

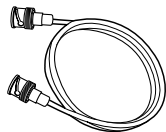

E

Installing the Camera

Installing on a PIPE (for SCC-C9302)

- Carefully read the 'Before Installation' section before starting installation.
 - All holes that are not used for installation must be closed up with the SCREWS provided in your ACCESSORY set as described in the installation HOLE section.

Installing the CAMERA bottom to a PIPE

- Connect the power cable and video cable, and then pull them into the PIPE. Assemble the screw helix (3/4" threaded) for the PIPE assembly of the CAMERA and screw helix (3/4" threaded) for the PIPE and fix the SET. (* Completely wrap the screw helix area of the PIPE with TEFLON TAPE to make it waterproof. Make sure that the cable does not get caught in the tape.)
- Adjust the LENS in the direction you want.
 - Disassemble the DOME COVER with the L WRENCH provided in your ACCESSORY set.
(Rotating clockwise will close the cover and rotating anti-clockwise will release it.)
 - Adjust the LENS in the direction you want.



Horizontal rotation

Vertical rotation

Backlash : Widen and lift the wings on both sides of the COVER outwards to remove the COVER, and then rotate the LENS. After finishing adjustment, reassemble the COVER by pushing it in until a click is heard.

E

Installing the Camera

E

- 3) Assemble the DOME COVER.(Use the L WRENCH to firmly adjust the BOLT into place to make it waterproof.)
 - To change the direction of the SAMSUNG LOGO on the DOME COVER,change the assemble location of the connection rubber and turn it back into place as in the following image. (For 180 • only)



Installing the CAMERA side to a PIPE

1. Pull the power cable and video cable from the PIPE assembly hole at the bottom of the CAMERA bottom,out through the PIPE assembly hole on the side.
- 1) Use a coin or slotted driver to turn the CAP BOLT assembled in the PIPE assembly hole on the side anti-clockwise and disassemble it from the CASE.



- 2) Take the power cable and video cable from the PIPE assembly hole at the bottom and push the cables through the hole to pass through the PIPE assembly hole on the side.



3. Use a coin or slotted driver to turn the CAP BOLT previously disassembled from the CASE clockwise to reassemble it.
 (Check to see if the O RING (P22 T2.4) is attached to the CAP-BOLT.

If there is no O RING, the product will not be properly waterproofed and may malfunction.)

4. Rearrange and pull the connected power cable and video cable into the PIPE. Assemble the screw helix (3/4" threaded)for the PIPE assembly of the CAMERA and screw helix (3/4" threaded)for the PIPE and fix the SET.

(* Completely wrap the screw helix area of the PIPE with TEFLON TAPE to make it waterproof. Make sure the cable does not get caught in the tape.)

5. Adjust the LENS in the direction you want.
 (For more information on adjusting the LENS, disassembling the DOME COVER and assembly methods,please refer to 'Installing the CAMERA bottom to a PIPE'in section no.3.)



E

Installing the Camera

Installing on the ceiling

E

- Carefully read the 'Before Installation' section before starting installation.
 - All holes that are not used for installation must be closed up with the SCREWS provided in your ACCESSORY set as described in the installation HOLE section.
- Attach the provided TEMPLATE to where you want to install the camera, and then drill a hole (diameter 5 mm, depth min.35 mm).
Completely insert the PLASTIC ANCHOR provided (HUD 5).
- Connect the power cable and video cable and then arrange the cables so they will not be damaged or jammed while installing the CAMERA.
- Disassemble the DOME COVER to install the CAMERA.
(For more information on disassembling the DOME COVER and assembly methods, please refer to 'Installing the CAMERA bottom to a PIPE' in section no. 3.)
- Install the CAMERA.
Match the installation hole on the CAMERA to the hole with the PLASTIC ANCHOR and then assemble the ASSY SCREW-TAPPING (TH M4 X 30) with an O RING on it into all 4 places.
(If there is no O RING, the product will not be properly waterproofed.)

For SCC-C9302

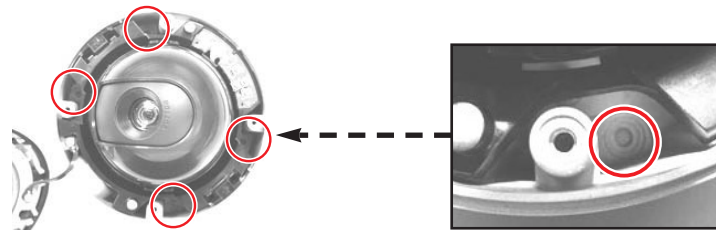

E

For SCC-C9302F

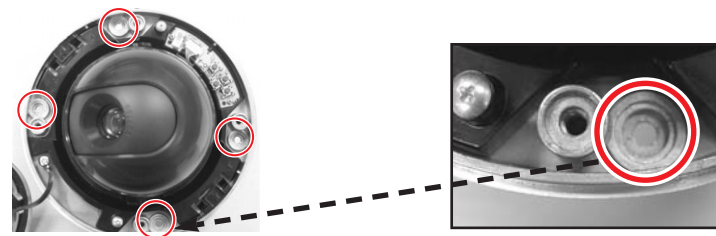

- Adjust the LENS to the direction you want and assemble the DOME COVER.
(For more information on adjusting the LENS and assembling the DOME COVER, please refer to 'Installing the CAMERA bottom to a PIPE' in section no. 3.)

Installing the Camera

Additionally Connecting the ALARM CABLE

1. To connect the ALARM CABLE, disassemble the DOME COVER.
(For more information on disassembling the DOME COVER and assemble methods, please refer to 'Installing the CAMERA bottom to a PIPE' in section no. 3.)
2. Disassemble the CAMERA bundle from the CASE.
 - 1) Unscrew the 2 SCREWS anti-clockwise.
 - 2) Pull the right and left levers inwards toward the arrow directions and then release the latch and disassemble the bundle.

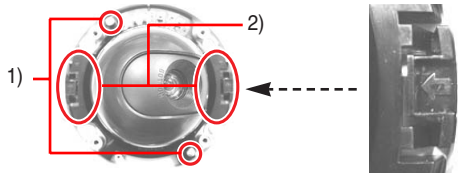

3. Pass the ALARM CABLE through the PIPE assembly hole of SCC-C9302 and then connect it to the ALARM TERMINAL of the PCB.
Remove the rubber stopper on the SCC-C9302F and then pass the ALARM CABLE again through this hole and connect it to the ALARM TERMINAL of the PCB.

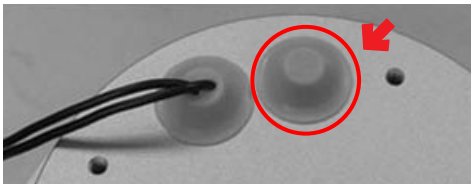

4. Reassemble the CAMERA bundle to the CASE.
(Fix the 3 grooves on the CAMERA bundle to the protrusion on the CASE and assemble as in the following image. There are arrows on the right and left grooves on the CAMERA bundle.)

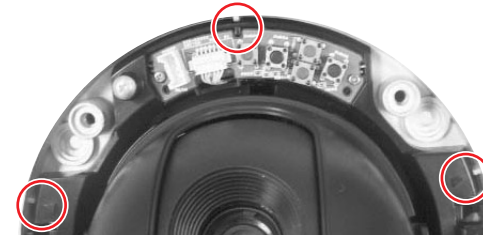

5. Adjust the LENS to the direction you want and assemble the DOME COVER.
(For more information on adjusting the LENS and assembling the DOME COVER, please refer to 'Installing the CAMERA bottom to a PIPE' in section no. 3.)

Connecting Cables and Checking Operations

1. First connect one end of the BNC cable to the VIDEO OUT.
2. Next, connect the other end of the BNC cable to the video input terminal of the monitor.

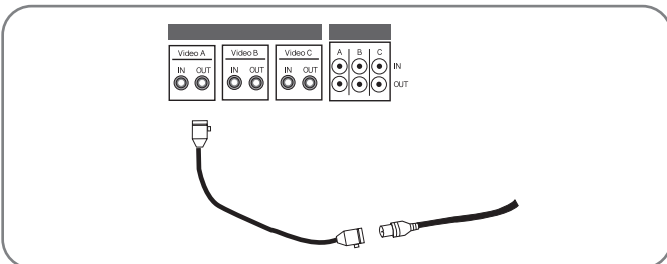

3. Then, plug in the power adapter. Use a "minus" screwdriver to connect one part of the power adapter consisting of two lines to the power input terminal of the Camera as follows. (GND: marked with a white line on the cable)

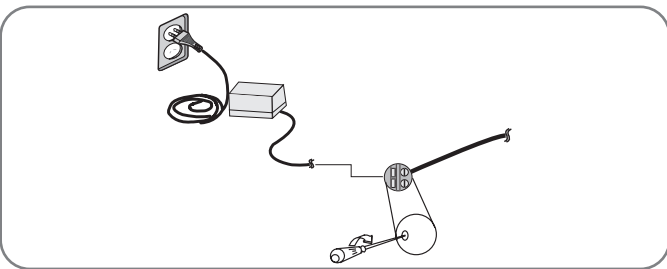

4. Decide on the type of power source you want to use and then adjust the power selection switch located at the bottom of the power adapter. Then, plug the power adapter into the power receptacle.
5. If the camera operates normally, the following screen will be displayed for 5 seconds before it disappears.

E

SAMSUNG	PROTOCOL
ADDRESS	0
TYPE	RS-485, HALF
BAUD RATE	9600
LENS	OK
ROM VER	1.000
EEP VER	1.000

6. When controlling an RS485, please check the following:
 - Communication Speed: 4800 bps ~ 38400 bps
 - Data Bit Number: 8 bits
 - Stop Bit Number: 1 bit
 - Parity Bit: None

Chapter 3

Setup Menu Overview

E

This chapter looks into the overall organization of the setup menus and explains their functions.



Structure of the Setup Menu

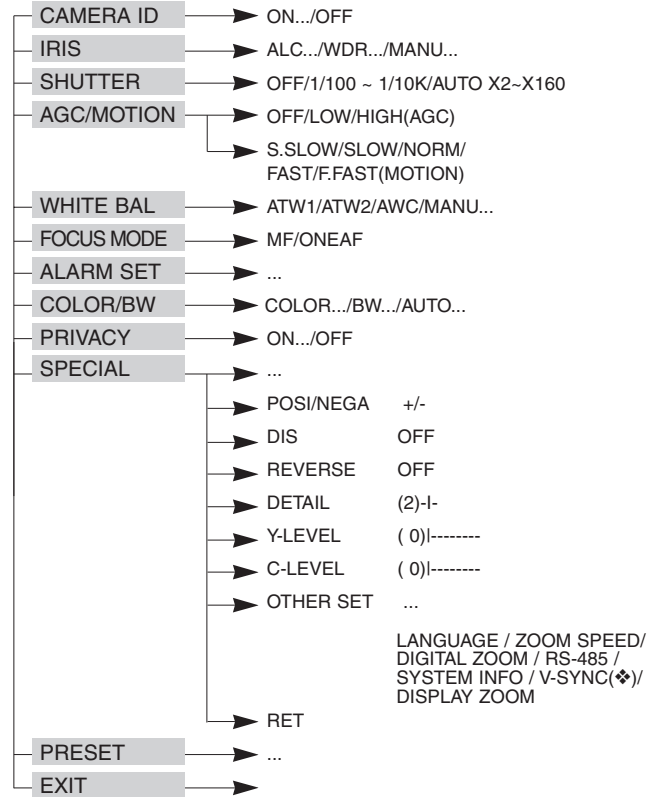

E

CAMERA MENU Organization

CAMERA ID

In the CAMERA ID menu, you may designate the CAMERA ID to be displayed in the monitor connected to a camera. Set the CAMERA ID menu to ON... and press [ENTER] and the CAMERA ID setup submenu will appear. The CAMERA ID may be created by up to 20 digits by using alphabets, numbers, and some special texts served by the submenu screen. You may locate the designated CAMERA ID on your own by using the LOCATION... submenu.

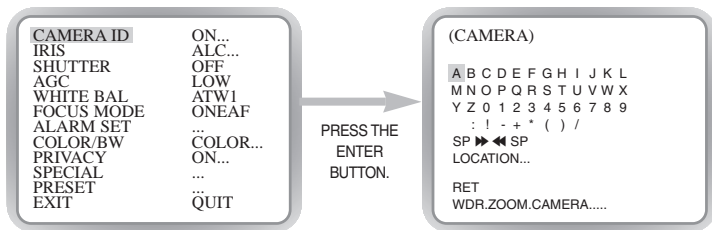

IRIS

ALC

Select ALC... from the IRIS menu and press [ENTER] and the BLC(Back Light Compensation) setup submenu will appear. If you use a general camera to photograph a subject under backlight or bright illumination, the subject will be shown dark on the monitor due to the backlight. BLC(Back Light Compensation) is used to prevent such a backlight problem to secure distinct images under bright illumination. Using the [Left, Right] keys, you can set up BOTTOM..., TOP..., LEFT..., RIGHT..., CENTER... 5 preset areas and the USER... function that can directly set the areas. For example, for the items in the BLC menu, you can confirm the preset BOTTOM area by pressing [ENTER] key in the BOTTOM... status.

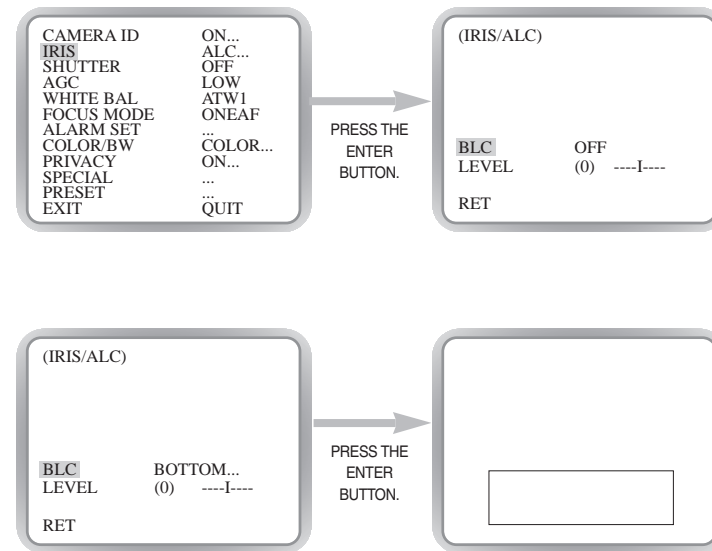

BLC

For items in the BLC menu, the user can set the size and location of the BLC area by pressing [ENTER] key after put the cursor on USER... using the [Left, Right] key. For SIZE items, you can use the [Up, Down, Left, Right] key to designate the SIZE, and then press the [ENTER] key. You can set the location for areas using the [Up, Down, Left, Right] key in the LOCATION.

CAMERA MENU Organization

E

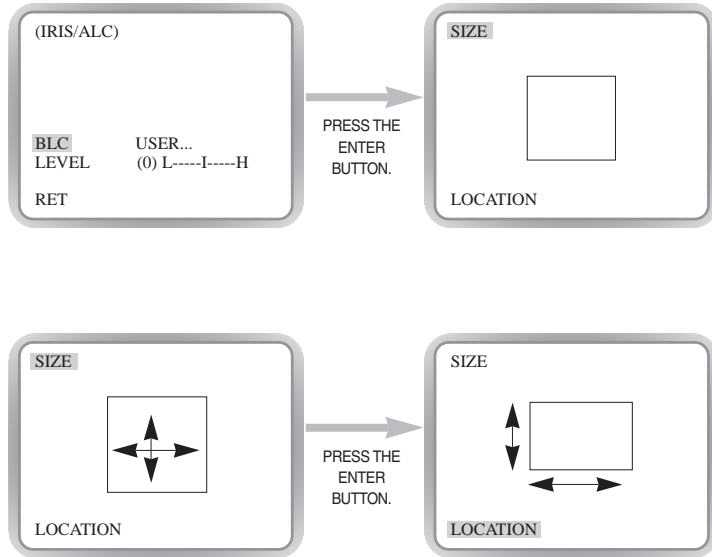

Use [Left, Right] key in the LEVEL menu to control the video output level(brightness).

WDR

WDR(Wide Dynamic Range) enlarges the advantage of a screen, mostly effective photographing both indoor and outdoor subjects simultaneously. In short, both subjects can be distinctly revived. Select WDR... and press [ENTER] to set up WDR LEVEL.

E

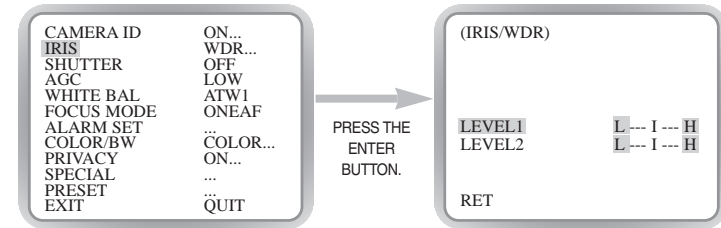

- LEVEL 1 : Controls the shutter speed while WDR operates.
- LEVEL 2 : Controls the whole brightness while WDR operates.

CAMERA MENU Organization

MANU

When you press [ENTER] key after selecting MANU in the IRIS item, an additional screen appears in which you can set manually opening or closing the IRIS.

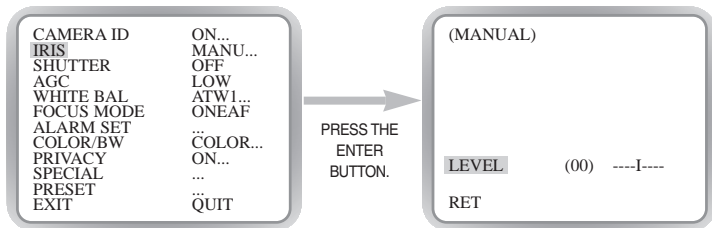

SHUTTER

In the SHUTTER menu, you may determine the fast electronic shutter speed or slow AUTO shutter speed. The fast electronic shutter supports 7 speeds from 1/100(1/120) sec. to 1/10K sec. to photograph a bright and quick moving image. The slow AUTO shutter supports about 10 speed from x2 to x160 to make an image projected to the screen more distinct and brighter by selecting the slow shutter speed. If you want the camera to sense the brightness and adjust the shutter speed accordingly, select a menu commencing with Slow AUTO Shutter. When SHUTTER is set to AUTO, AGC will be replaced with MOTION. If you keep pressing and fi in the SHUTTER menu, the speed will change in the following sequence.

CAMERA ID	ON...
IRIS	ALC...
SHUTTER	OFF
AGC	LOW
WHITE BAL	ATW1
FOCUS MODE	ONEAF
ALARM SET	...
COLOR/BW	COLOR...
PRIVACY	ON...
SPECIAL	...
PRESET	...
EXIT	QUIT

→ OFF → AUTOX2 → AUTOX4 → AUTOX6 → AUTOX8 →
 AUTOX12 → AUTOX16 → AUTOX20 → AUTOX40 →
 AUTOX80 → AUTOX160 → OFF → 1/100 → 1/250 →
 1/500 → 1/1000 → 1/2000 → 1/4000 → 1/10K → OFF

❖ When the IRIS mode is set to WDR, only the following modes are available.

→ OFF → AUTOX2 → AUTOX4 → AUTOX6 → AUTOX8 →
 AUTOX12 → AUTOX16 → AUTOX20 → AUTOX40 →
 AUTOX80 → AUTOX160 → OFF

CAMERA MENU Organization

E

- ❖ The DIS feature is unavailable while setting the AUTO slow shutter. If you set SHUTTER to between AUTO X4... and AUTO X128..., FOCUS mode will be displayed as "MF"(the product can operate only in MF mode). You can't adjust the settings manually.
If you set it to OFF, 1/100 ~1/10K or AUTO X2..., the product will recover the previous FOCUS mode.
- ❖ If you set SHUTTER to between AUTO X2 and AUTO X128, DIS will be displayed as "----" (it can only operate in Off mode). You can't adjust the settings manually. If you set it to OFF or 1/100 ~1/10K, the product will recover the previous settings of DIS.

AGC/MOTION

In the AGC (Automatic Gain Control) option, you can specify whether to automatically control the GAIN when the obtained video is below a certain level of brightness because it was recorded under insufficient lighting. To automatically control the GAIN, set the AGC option to LOW or HIGH. Otherwise, set it to OFF. If the you set the AGC option to LOW, the maximum GAIN of the AGC will be set to low, and if set to HIGH, the maximum GAIN will be set to high. If the SHUTTER is in AUTO mode, AGC is switched to MOTION. In MOTION, use the [left,right] key to select "S.SLOW / SLOW / NORMAL / FAST / F.FAST".

CAMERA ID	ON...
IRIS	ALC...
SHUTTER	OFF
AGC	LOW
WHITE BAL	ATW1
FOCUS MODE	ONEAF
ALARM SET	...
COLOR/BW	COLOR...
PRIVACY	ON...
SPECIAL	...
PRESET	...
EXIT	QUIT

<AGC>

WHITE BAL

You can select one of four modes for white balance adjustment as follows:

- ATW1/ATW2(Auto-Tracing White Balance Mode): In these modes, the color temperature is monitored continuously and thereby white balance is set automatically. The following are the approximate supported color temperature ranges in these modes.
ATW1 : 2500K ~ 9300K(* 1)
ATW2 : 2000K ~ 10000K(Mode recommended for sodium lighting)(* 2)
- * 1. If the color temperature is out of this range in ATW1 mode,proper white balance may not be obtained. In that case, select ATW2 mode.
- * 2. In ATW2 mode, if one color is dominated in the shooted area, the color can be displayed differently. Therefore, select the mode which is appropriate for the environment.
- AWC(Auto-Tracing White Balance Control): In this mode, accurate white balance is obtained by pressing [ENTER] while having a white paper in front of the camera. White Balance data will be maintained after set it once. AWC mode is best in locations where the color temperature of light source is constant.
- MANU : If WHITE BAL menu is set to MANU mode, the user can set the white Balance considering the current illumination. Select MANU item and press [ENTER], the sub screen where you can select Manual White Balance will be shown. Use the left/right keys to select 3200K, 5600K or OFF(USER) mode in the PRESET menu.
- * 3200K : Set color temperature to 3200K
- * 5600K : Set color temperature to 5600K
- * USER : Choose out a proper value from the RED and BLUE graph for color and temperature setup.

E

CAMERA MENU Organization

E

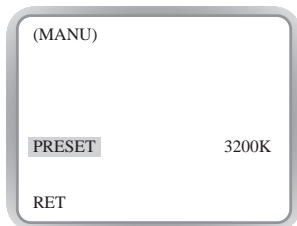

FOCUS MODE

The FOCUS MODE menu performs MF(Manual Focus), and ONEAF(One Auto Focus).

- MF : You can manually adjust the focus.
- ONEAF : Focusing will take about 5 seconds in ONEAF mode. When turned off, it is same to the MF mode.

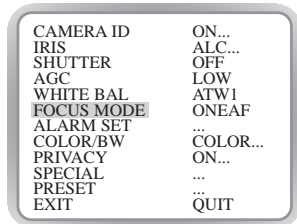

ALARM SET

The Alarm Set feature consists of one Alarm In and one Alarm Out, which detects an Alarm In signal from an external sensor and moves to the position pre-defined by the Position Set for the alarming process. Then, it returns to the original position. And it also transfers the Alarm Out signal to external devices. When as much time as the Dwell Time in that position has passed, it will go back to the original position. If no particular position is defined by the Position Set, it will move to the maximum TELE.

E

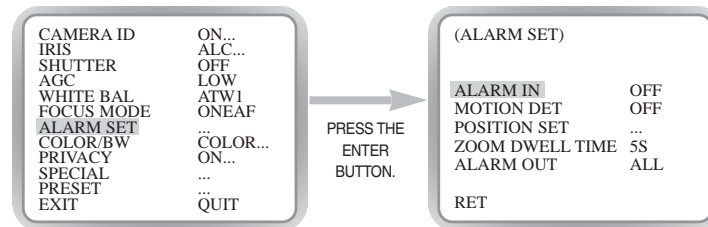

MOTION DET detects any motion. Set up this function during no human movement to detect break-in. Once detected, an ALARM signal will be given for 5 seconds. As MOTION DET detects any motion, so it can set up the motion detection sensitivity. Select ON... and press [ENTER] and the MOTION DET submenu screen will appear.

If you select ON and press the ENTER button, the MOTION DET screen will come up. You can set the AREA to which the Motion Detection function will be applied to either PRESET or USER. If you set the AREA option to PRESET, the Motion Detection function will be applied to the areas preset as factory defaults. If you set the AREA option to USER and press the ENTER button, you can change the area size and position and select the area where you want to apply the Motion Detection function. You can specify the size of the area by using the UP, DOWN, LEFT, and RIGHT buttons. If the area is not flashing, press the ENTER button. When the area starts flashing, use the UP, DOWN, LEFT and RIGHT buttons to specify the location of the area. Use the ENTER button and the UP, DOWN, LEFT, and RIGHT buttons to specify the size of the area and to position the area. Press the ENTER button again to exit the AREA setting menu. You can use the SENSITIVITY option to set the motion detection sensitivity. The higher the setting, the more sensitive the motion detection.

CAMERA MENU Organization

E

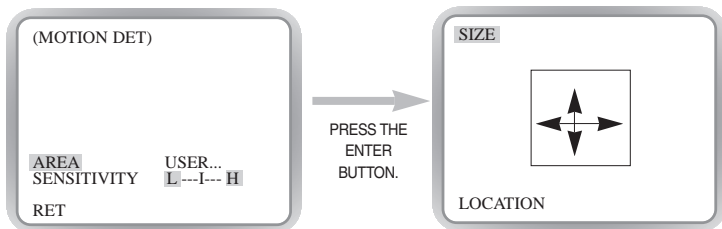

- ❖ 1. MOTION detection function operates based on the brightness change within the setup region.
Therefore, erroneous operation may occur depending on the brightness difference between the background and the object that is being taken, or the status of the area setup, etc.
- ❖ 2. The followings may occur in a camera with built-in zoom.
 - When the zoom rate becomes closer to the TELE side, the edges of the screen may become dim.
 - When connected to a DVR or an LCD monitor, the screen corners may be obstructed.

COLOR/BW

COLOR/BW turns IR(Infrared) Filter on or off. In the poor illumination environment, turns IR Filter off to raise the sensitivity to the same level as an black-and-white camera while in the good illumination environment, turns it on to convert to the COLOR mode in the normal screen condition to lower the sensitivity.

➔ COLOR

This is the IR Filter ON mode with a normal color screen.

You can press the [Enter] key to set the COLOR GAIN LEVEL. And when the AGC function is on, you can set the AGC COLOER LEVEL.

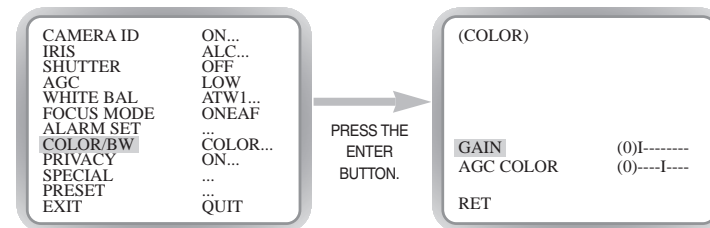

E

CAMERA MENU Organization

➤ BW

This is the IR Filter OFF mode, black-and-white (with the same sensitivity as a black-and-white camera). Select BW... and press [Enter] and the BW submenu will appear. You may determine to sent out BURST signals by ON or OFF setting in this submenu.

- ❖ WHITE BAL will be marked --- so that setup is unavailable.
- ❖ In AUTO mode, AGC menu will be displayed as "---" and you cannot change it manually,

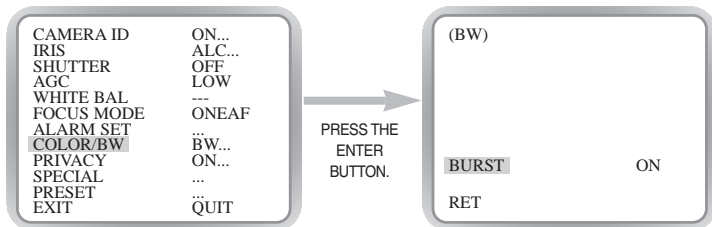

➤ AUTO

Depending on illumination, it is automatically switched to the COLOR or BW mode. In the poor illumination environment, turns IR Filter off to convert to the Black-and-White mode for better sensitivity and in the good illumination environment, turns it on to convert to the COLOR mode for worse sensitivity. Select AUTO and press [Enter] and the AUTO BW submenu will appear to control the BW level. Depending on ON or OFF, the BURST signal may output or no.

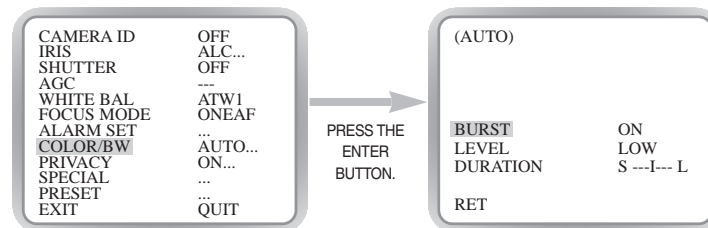

- BURST ON : The color burst signal is output together with black and white composite video signal.
- BURST OFF : The color burst signal is not output.
- LEVEL : You can set the brightness level that changes from COLOR mode to BW mode in 3 steps : LOW, MEDIUM, and HIGH.
- DWELL TIME : Set the HOLDING time for switching between COLOR and BW mode depending the changes in the amount of light. You can set the HOLDING time to 10sec (S), 30sec, 60sec, or 300sec(L).

In AUTO mode, AGC will operates in high speed mode, and you cannot change it manually, as it is indicated by "---".

CAMERA MENU Organization

PRIVACY

This function designates an area that may violate PRIVACY and hides it when the camera shoots a screen including the area to protect Privacy. Up to 8 PRIVACY ZONES are available for setup. After PRIVACY menu setup, press ENTER to enter the PRIVACY MAP screen. Now, press UP/DOWN/LEFT/RIGHT key to choose one out of PRIVACY 0~7 and press ENTER to enter the PRIVACY setup menu.

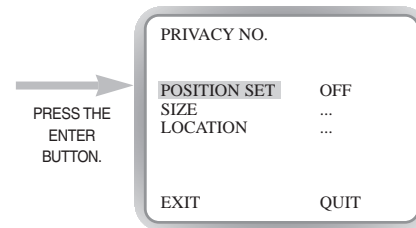
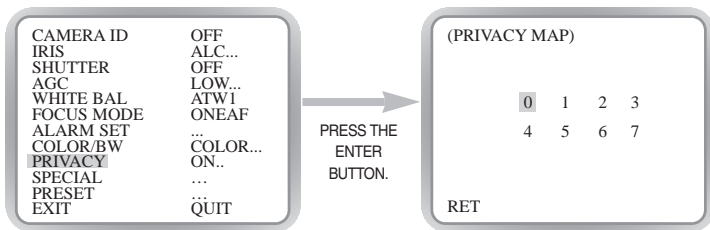

You shall set up the position of ZOOM/FOCUS in the PRIVACY ZONE area from the POSITION SET menu. Press UP/DOWN/LEFT/RIGHT key to size the PRIVACY ZONE area from the SIZE menu. Press UP/DOWN/LEFT/RIGHT key to locate the PRIVACY ZONE area from the LOCATION menu.

❖ The rim of the screen cannot be hidden by the PRIVACY ZONE area. Please be careful for setup.

CAMERA MENU Organization

SPECIAL

In SPECIAL menu, you can set the settings related to the VIDEO signals and various additional functions.

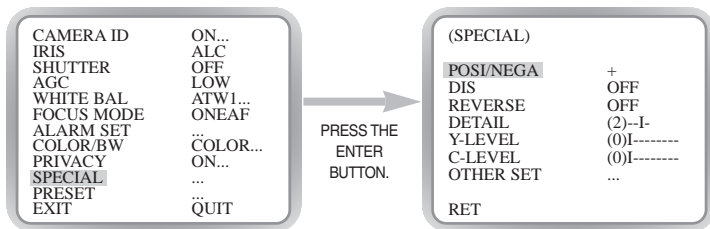

- POSI/NEGA : Output as it is or mirror the video brightness signal.
- DIS : Digital Image Stabilization. Compensates hand shivering errors.
- REVERSE : Mirrors video signals horizontally, vertically, or both.
- DETAIL : Controls the horizontal or vertical distinction.
- YLEVEL : It is used to set the levels for the Sync signal and the entire brightness signal of the video signal.

❖ It is recommended to deactivate the DIS function in the no vibration environment.

- C-LEVEL : It is used to set the levels for the Burst signal and the entire colour signal of the video signal.
- OTHER SET : In OTHER SET menu, you can adjust LANGUAGE, ZOOM SPEED, D-ZOON, RS-485, SYSTEM INFO..., and V-SYNC function, etc. When you press [ENTER] key from OTHER SET menu, the OTHER SET additional menu screen appear.

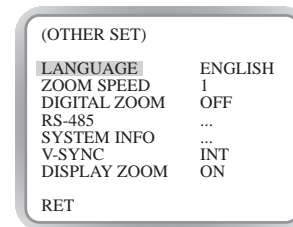
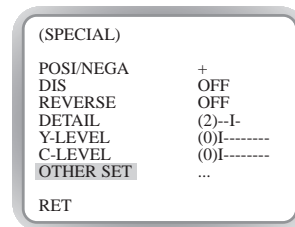

- LANGUAGE : This function selects a language for MENU setup. Press LEFT/RIGHT key to choose English, French, Spanish, or Japanese and the selected language will be applied to the full screen.

CAMERA MENU Organization

- ZOOM SPEED : Use [Left, Right] key in the ZOOM SPEED menu to set the speed as follows.
- ZOOM SPEED 1 : About 17Sec. from X 1 to X 12(Slowest)
- ZOOM SPEED 2 : About 10Sec. from X 1 to X 12(Slow)
- ZOOM SPEED 3 : About 6Sec. from X 1 to X 12(Fast)
- ZOOM SPEED 4 : About 3Sec. from X 1 to X 12(Fastest)
- D-ZOOM : Sets up the Digital Zoom magnification ratio up to x10.
- RS-485 : Sets up RS-485 Communication Protocol, Address, and Baud Rate.

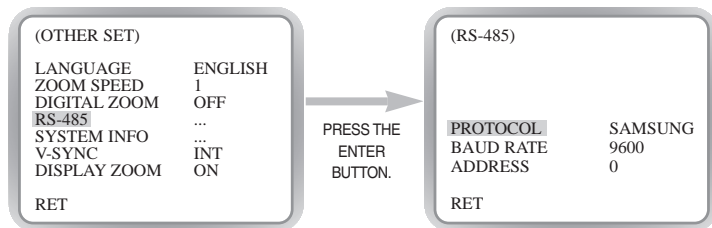

- SYSTEM INFO : You can confirm settings related to the RS-485 communication, product serial number, and the software version.

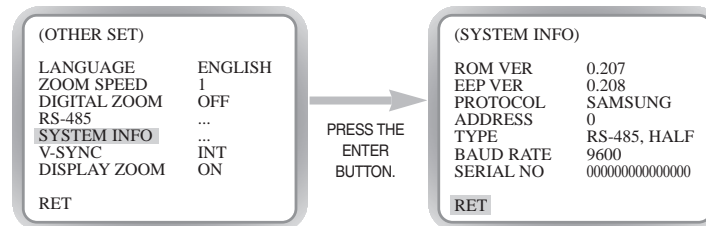

- V-SYNC : INT shall be selected to use internal synchronization. LINE... is used to synchronize several camera phases for the multi camera operation by using an external signal(AC signal). As there may be a slight deviation between sets, adjusts PHASE to overcome this handicap. When you use AC power source, V-SYNC is available. Select LINE... and press [ENTER] and the PHASE control submenu will appear. The PHASE control ranges from -106H to +106H as for NTSC and from -138H to +138H as for PAL.

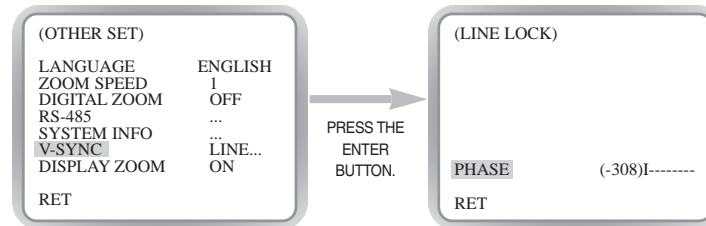

❖ When a DC power is supplied, V-SYNC menu will be displayed as --- and you cannot make any settings.

CAMERA MENU Organization

PRESET

Select the PRESET menu and press [ENTER] and the PRESET MAP submenu screen will appear.

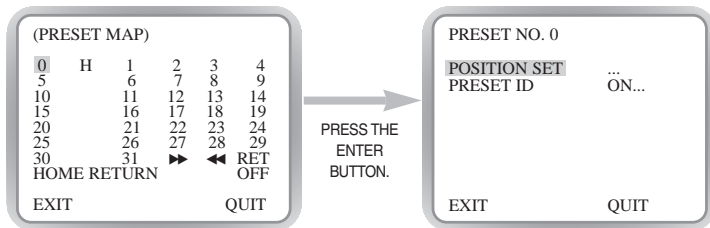

Select the PRESET number and press [ENTER] and the above screen will appear.

- POSITION SET : Memorizes the position of ZOOM or FOCUS.
- PRESET ID : Designates the ID on the basis of the PRESET position as the CAMERA ID.

❖ HOME RETURN automatically returns to the HOME position should there is no key input for a certain time. The HOME position is set to PRESET 0 if it is saved or Off if not.

HOME RETURN Time Setup

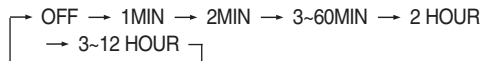

EXIT

The EXIT menu is used to terminate the CAMERA SETUP menu.

- QUIT : Select to ignore any changes you have made and restore the previously saved settings.
- SAVE : Select to save the settings that have been changed so far.
- PRESET : Ignores any change and returns to the default of the CAMERA menu as set for the product delivery. (RS-485, PRESET, PRIVACY MENU excluded)

E

CAMERA ID	ON...
IRIS	ALC...
SHUTTER	OFF
AGC	LOW
WHITE BAL	ATW1
FOCUS MODE	ONEAF
ALARM SET	...
COLOR/BW	COLOR...
PRIVACY	ON...
SPECIAL	...
PRESET	...
EXIT	QUIT

SCC-C9302

E

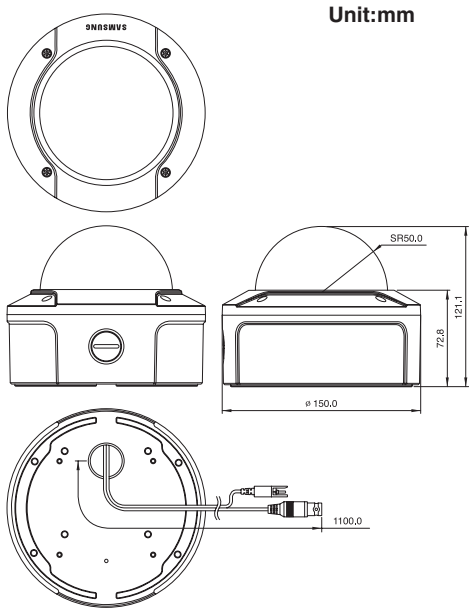

SCC-C9302(F)

E

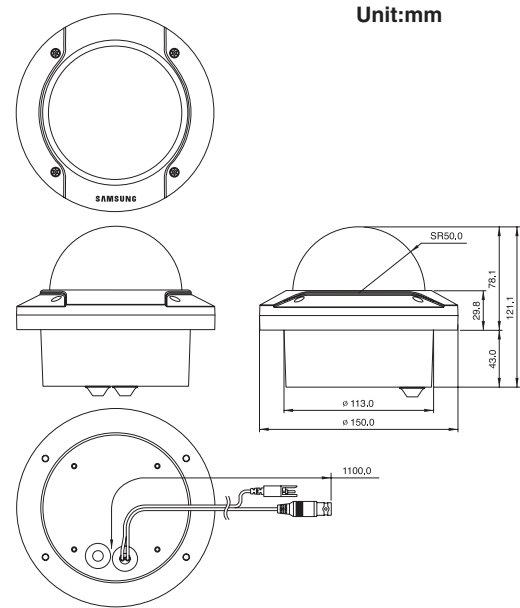

External Connector Pin Specifications

CN 52 : Camera Power Input and Video Signal Output

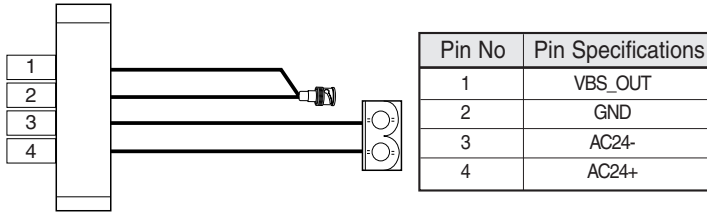

CN 51 : RS485 Control and Alarm Output

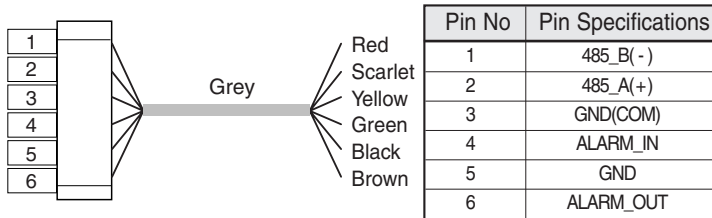

Product Specifications

ITEM	DESCRIPTION
Product Type	Anti-Vandal Dome Camera
Power Source Voltage	AC 24V \pm 10% (NTSC:60Hz \pm 0.1Hz, PAL:50Hz \pm 0.1Hz), DC12V +10% ~ -5%
Power Consumption	Approx. 6W
Broadcast System	NTSC(PAL) Standard Color System
Imaging Device	1/4 inch IT S-HAD CCD
Effective Pixel	NTSC : 768(H) X 494(V) PAL : 752(H) X 582(V)
Scanning Method	NTSC : 525 Line, 2:1 Interlace PAL : 625 Line, 2:1 Interlace
Line Frequency	Horizontal(NTSC) :15,734 Hz(INT) / 15,750 Hz(L/L) Horizontal(PAL) :15,625 Hz(INT) / 15,625 Hz(L/L) Vertical(NTSC) : 59.94 Hz(int) / 60 Hz(L/L) Vertical(PAL) : 50 Hz(int) / 50 Hz(L/L)
Synchronization Method	INT/Line Lock
Resolution	480 TV Lines
S/N Ratio	52dB (AGC Off)
Minimum Scene Illumination	COLOR : 0.2 Lux (SENSE UP X4) / 0.005 Lux (SENSE UP X160) BW : 0.02 Lux (SENSE UP X4) / 0.0005 Lux (SENSE UP X160)
Color Temperature	ATW/AWC/Manual MODE (3200°K, 5600°K, R/B Gain Control)
Electronic Shutter	Off, 1/100(NTSC), 1/120(PAL), 1/250, 1/500, 1/1K, 1/2K, 1/4K, 1/10K sec

Product Specifications

ITEM	DESCRIPTION
Back Light Compensation	Off/On (Area Setting)
Sense Up	Off/Auto 2x~160x
Digital Zoom	Off/On(x10), PIP
Motion Detection	Off/On (Area/Sensitivity Setting)
Video Control	POS/NEGA, MIRROR, Detail Setting
Signal Output	Composite Video Out : 1.0 Vp-p 75 ohms/BNC
Lens	Focal length : 3.6 ~ 43.2 mm Aperture : F1.8(Wide), F2.6(Tele) MOD(Minimum Object Distance) : 1 m Alarm input : 1 in / Alarm output : 1 out
ALARM	
Remote Control	RS485 (Half Duplex)
Operating Temperature	-10°C ~ +50°C (14°F~122°F)
Operating Humidity	~90%
Physical Size	150(ø) x 121 mm
Weight	SCC-C9302 : 1.1Kg / SCC-C9302F : 0.88Kg (Net Weight)

E

Correct Disposal of This Product (Waste Electrical & Electronic Equipment)

(Applicable in the European Union and other European countries with separate collection systems)

This marking shown on the product or its literature, indicates that it should not be disposed with other household wastes at the end of its working life. To prevent possible harm to the environment or human health from uncontrolled waste disposal, please separate this from other types of wastes and recycle it responsibly to promote the sustainable reuse of material resources.

Household users should contact either the retailer where they purchased this product, or their local government office, for details of where and how they can take this item for environmentally safe recycling.

Business users should contact their supplier and check the terms and conditions of the purchase contract. This product should not be mixed with other commercial wastes for disposal.





Part No. AB68-00576A(00)