

PROFESSIONAL PRESET DECODER FOR PTZ

Model : CCDCPS1

**Support Long Distance / LAN / INTERNET control
of Pan Tilt Zoom, Preset Location, AUX – Wiper /
On & Off, Output DC to Camera,.....**

Operation Manual



Kindly read this manual carefully before operate this equipment.

Table of contents

1. Product Description	2
2. Features	2
3. Specification	2
4. Pan/Tilt setting	2
5. Lens setting	2
6. Auxiliary control	2
7. Protocol setting	2
8. Baud rate setting	3
9. ID Address setting	3
10. System connections	4
11. Connections and setup	5
12. Test function	5
13. Trouble Shooting	7
14. Appendix I- Iris control settings for KODICOM RX & KRE-301RX protocol.....	7
15. Appendix II-ID address setting for KODICOM.....	8

Warning:

Please choose the Pan/Tilt voltage correctly!

The voltage is too high will lead to the fact that the Pan/Tilt damaged.

Please use twisted-pair cable for wiring.

1. Product Description

PTZ are used with keyboard controller and matrix systems to control pan, tilt, zoom, focus, and iris and auxiliary functions in surveillance system. Receivers are RS485 or Manchester communication, it is compatible with multi-protocol.

2. Features

- Built in watch dog function, multi-protocol setting
- Two auxiliary relays for light, wiper and camera power controlling
- Fully optical isolation, auto reset function in strong reference environment
- Baud rate options, 0-64-256 ID setting
- Static resistant, high voltage and thunder proof design
- Optional power source provided, AC220V, AC24V, DC12
- AC220V, AC24V voltage optional for pan/tilt unit (the factory default setting is AC24V)
- Adjustable lens voltage form 6V to 12V for speed adjusting (the factory default setting is 8V)

3. Technical parameter

Power supply: AC220V / 50HZ

Power consumption: 28—50W

Pan/Tilt voltage: AC220V, AC 24V optional

Pan/Tilt drive power consumption: AC220V / 2A or AC24V / 800mA

lens voltage: 5—12V options

Provided power source: AC220V/2A、AC24V / 500mA、DC12V / 600mA

Auxiliary relay: 2 NO auxiliary(AUX1 and AUX2), the capacity is AC220V / 5A

Communication: RS485, Manchester

Protocol: multi-protocol setting (we welcome your request for protocol customization)

Operating environment: indoor(—10℃~70℃), outdoor(—40℃~85℃)

Transmission distance: 1200-1500meters

ID setting: 0—63—255(Can be customized)

4. Pan/tilt setting

The receiver can control Pan/tilt up, down, left, right movements and auto function. There are two kinds of voltage optional, AC220V & AC24V (warning: higher voltage will lead to the fact that Pan/Tilt be damaged).













5.Lens setting

The receiver can control the iris, focus and zoom of lens. The lens output voltage can be varied from 6 to 12 volts DC with a potentiometer.The operator can adjust the speed of lens via lens power,the voltage is higher then the speed is faster.

6.Auxiliary control

There are 2 auxiliary relay normally open(AUX1&AUX2).

7. Protocol setting

NO.	Protocol	switch position	Baud rate
0	PELCO-D HC	ON  OFF 1 2 3 4	PELCO-D 2400
1	HY	ON  OFF 1 2 3 4	9600
2	VICON (surveyor 99)	ON  OFF 1 2 3 4	4800
3	YAAN	ON  OFF 1 2 3 4	9600
4	PELCO-P	ON  OFF 1 2 3 4	9600
5	MINGWEI	ON  OFF 1 2 3 4	9600
6	SAMSUNG	ON  OFF 1 2 3 4	9600
7	KODICOM-RX KRE-301RX	ON  OFF 1 2 3 4	9600
8	DH/KCL/LULINWANG	ON  OFF 1 2 3 4	9600/19200
9	NEOCAM	ON  OFF 1 2 3 4	9600
10	PIH1016	ON  OFF 1 2 3 4	2400
11	B01	ON  OFF 1 2 3 4	9600
12	RM110 / S1601	ON  OFF 1 2 3 4	9600
13			
14			
15			

Note: The DV7XX series receiver provides IRIS control for KODICOM&PIACSO protocol, please refer to appendix I for detail setting.

8. Baud rate setting



NO.	Baud rate	Switch Position	NOTE
0	9600	ON <input type="checkbox"/> <input type="checkbox"/> OFF 1 2	According to different protocol, it can select the correct one automatically
1	4800	ON <input type="checkbox"/> <input type="checkbox"/> OFF 1 2	
2	2400	ON <input type="checkbox"/> <input type="checkbox"/> OFF 1 2	
3	1200	ON <input type="checkbox"/> <input type="checkbox"/> OFF 1 2	

9.ID Address Setting

0=OFF

1=ON

Camera	Switch Position								Camera	Switch Position							
ID	1	2	3	4	5	6	7	8	ID	1	2	3	4	5	6	7	8
1	0	0	0	0	0	0	0	0	33	0	0	1	0	0	0	0	0
2	0	0	0	0	0	0	0	1	34	0	0	1	0	0	0	0	1
3	0	0	0	0	0	0	1	0	35	0	0	1	0	0	0	1	0
4	0	0	0	0	0	0	1	1	36	0	0	1	0	0	0	1	1
5	0	0	0	0	0	1	0	0	37	0	0	1	0	0	1	0	0
6	0	0	0	0	0	1	0	1	38	0	0	1	0	0	1	0	1
7	0	0	0	0	0	1	1	0	39	0	0	1	0	0	1	1	0
8	0	0	0	0	0	1	1	1	40	0	0	1	0	0	1	1	1
9	0	0	0	0	1	0	0	0	41	0	0	1	0	1	0	0	0
10	0	0	0	0	1	0	0	1	42	0	0	1	0	1	0	0	1
11	0	0	0	0	1	0	1	0	43	0	0	1	0	1	0	1	0
12	0	0	0	0	1	0	1	1	44	0	0	1	0	1	0	1	1
13	0	0	0	0	1	1	0	0	45	0	0	1	0	1	1	0	0
14	0	0	0	0	1	1	0	1	46	0	0	1	0	1	1	0	1
15	0	0	0	0	1	1	1	0	47	0	0	1	0	1	1	1	0
16	0	0	0	0	1	1	1	1	48	0	0	1	0	1	1	1	1
17	0	0	0	1	0	0	0	0	49	0	0	1	1	0	0	0	0
18	0	0	0	1	0	0	0	1	50	0	0	1	1	0	0	0	1
19	0	0	0	1	0	0	1	0	51	0	0	1	1	0	0	1	0
20	0	0	0	1	0	0	1	1	52	0	0	1	1	0	0	1	1
21	0	0	0	1	0	1	0	0	53	0	0	1	1	0	1	0	0
22	0	0	0	1	0	1	0	1	54	0	0	1	1	0	1	0	1
23	0	0	0	1	0	1	1	0	55	0	0	1	1	0	1	1	0
24	0	0	0	1	0	1	1	1	56	0	0	1	1	0	1	1	1
25	0	0	0	1	1	0	0	0	57	0	0	1	1	1	0	0	0
26	0	0	0	1	1	0	0	1	58	0	0	1	1	1	0	0	1
27	0	0	0	1	1	0	1	0	59	0	0	1	1	1	0	1	0

28	0	0	0	1	1	0	1	1		60	0	0	1	1	1	0	1	1
29	0	0	0	1	1	1	0	0		61	0	0	1	1	1	1	0	0
30	0	0	0	1	1	1	0	1		62	0	0	1	1	1	1	0	1
31	0	0	0	1	1	1	1	0		63	0	0	1	1	1	1	1	0
32	0	0	0	1	1	1	1	1		64	0	0	1	1	1	1	1	1

10. System connections

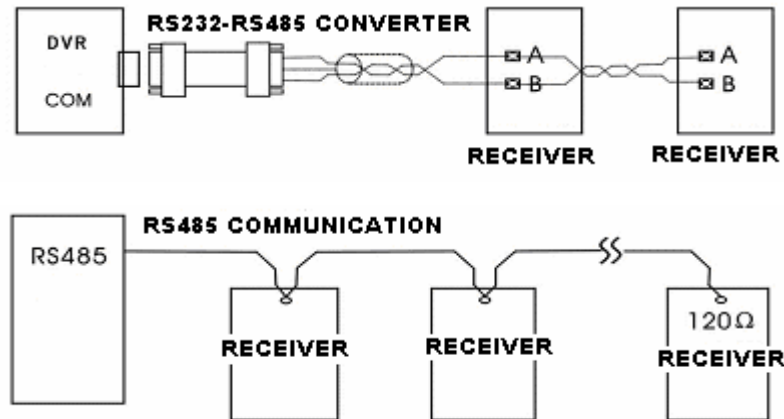

Instruction:

1. Use twist pair cable for correct connection per RS485 communication standard, otherwise the communication distance will be shorten significantly if using parallel cable.
2. The receiver is designed for “star ” and “daisy chain” connection, the terminals marked A and B are RS485 signal output ports which is to connect RS485 devices, wrong connection is not allowed.
3. When a lot of receivers need to connect together, a 120-ohm resistor must be connected in parallel between the terminal marked A and B on the last piece of equipment on the line.

11. Connections

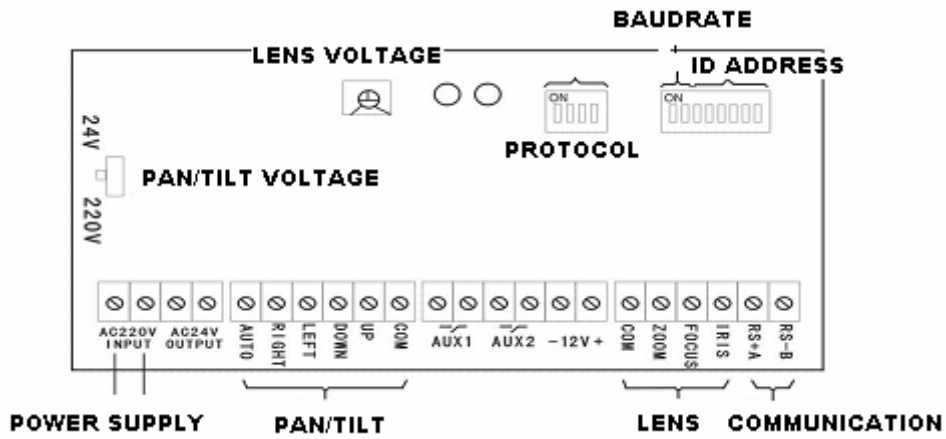

Economy Type Receiver Connection Diagram

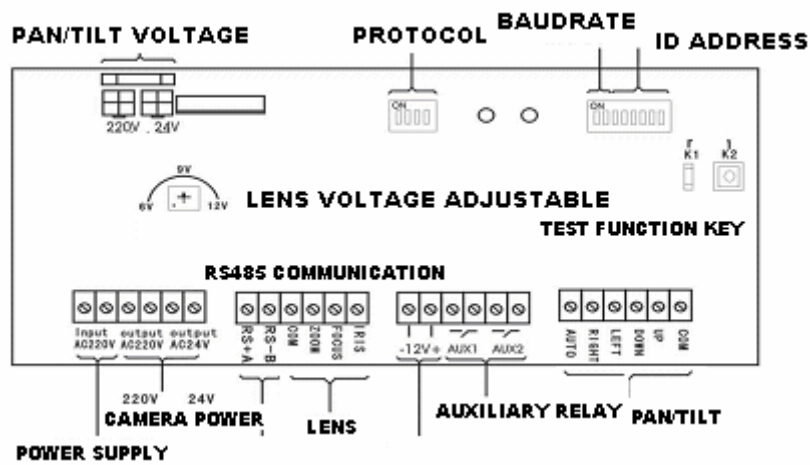

Standard Type Receiver Connection Diagram

12.The test function instruction

The receiver test function is to test whether the pan/tilt and lens function is functional. There are 2 test function keys (K1&K2) on the main board. Please refer to the following table1 for DIP switch setting..

Table1,DIP switch setting (ON=1,OFF=0)

NO.	Function	Switch Position			
		5	6	7	8
0	Pan Up	0	0	0	0
1	Pan Down	0	0	0	1
2	Tilt Left	0	0	1	0
3	Tilt Right	0	0	1	1
4	Zoom In	0	1	0	0
5	Zoom Out	0	1	0	1
6	Focus Near	0	1	1	0
7	Focus Far	0	1	1	1
8	Iris+	1	0	0	0
9	Iris-	1	0	0	1
A	AUX1	1	0	1	0
B	AUX2	1	0	1	1

Test procedure:

- 1) Short circuit K1 to enter the testing mode, then the red LED blinks.
- 2) Set the DIP switch to the related pan/tilt and lens function, then short circuit the K2 or press the K2 to conduct the test.
- 3) If the function is functional the red LED stays illuminated.
- 4) After test, remove the short wires and restore the DIP switch to the original setting. The receiver back to normal working status.

13. Trouble shooting

Trouble	Analysis and solution
LED does not illuminate after powered up	<ol style="list-style-type: none"> 1. Check the power supply to see if it is connected, or confirm if it is AC 220 volts. 2. Check to see if the fuse is damaged. 3. Check to see if the power supply has been cut off.
The pan/tilt & lens are uncontrollable	<ol style="list-style-type: none"> 1. The control cables are connected wrongly or the connection is not good in contact. 2. Check to see if the camera DIP switch setting is correct. 3. Check to see if the communication distance over 1200 meters, add a RS485 repeater or

equivalent to extend.

Appendix I-Iris control settings for KODICOM RX & KRE-301RX Protocol

Since the PICASO &KODICOM digital video recorder software has no iris control function, the DV7xx series receiver provides the detail iris control setting.

Operation procedures:

- For KODICOM digital video recorder

- a) Select KRE-301RX protocol
- b) Switch the wiper on
- c) Use focus button to conduct iris control
- d) Switch the wiper off

- For PICASO digital video recorder

- a) Select KODICOM RX protocol
- b) The operation procedure as same as above KODICOM DVR.

Appendix II-ID address setting for KODICOM

ID	Switch Position						ID	Switch Position					
	3	4	5	6	7	8		3	4	5	6	7	8
0	0	0	0	0	0	0	9	0	0	1	0	0	1
1	0	0	0	0	0	1	10	0	1	0	0	0	0
2	0	0	0	0	1	0	11	0	1	0	0	0	1
3	0	0	0	0	1	1	12	0	1	0	0	1	0
4	0	0	0	1	0	0	13	0	1	0	0	1	1
5	0	0	0	1	0	1	14	0	1	0	1	0	0
6	0	0	0	1	1	0	15	0	1	0	1	0	1
7	0	0	0	1	1	1	16	0	1	0	1	1	0
8	0	0	1	0	0	0							