

Indoor and Outdoor Decoder

MODEL : CCDC02

Installation and Operation Guide



**Prior to use of this product, please read carefully this operation guide!
Must abide by entire operating rules!**

Warning:

Non-professionals are prohibited privately to disassemble equipment or replace parts and components!

To prevent fire or electric shock, do not place this equipment in watery or wet place!(except waterproof type equipment)

Prior to use of this product, please check carefully the provided power supply voltage!

Attention:

Prior to power turn-on, please check carefully whether voltage jumper wire of cradle head conform to the voltage of cradle head!

To guarantee safety communication, please jumper connects at the farthest end of 485 communications the 120 Ω load resistance jumper wire of decoder!

Ex-factory cradle head voltage is set as 24VAC!

Ex-factory lens voltage is set as 12VDC!

Notice:

The indoor type decoder produced by this company is not waterproof. Outdoor type decoder is waterproof. If inappropriate installation causes the entrance of water into equipment, our company is not responsible for the responsibility of guaranteeing to keep equipment in good repair!

Contents

- General Situation**
- Product Features**
- Wiring Description**
- Choose the Driving Voltage of Cradle Head**
- Adjust the Driving Voltage of Lens**
- Set Especial Protocol and Communication Baud Rate**
- Set Decoder Address**
- Set Wiper Drive Mode**
- Technical Parameters**
- Analysis and Solution of Common Faults**

- General Situation**

Through many years' R&D and engineering practice, our company produces new generation decoder on the basis of former decoders. This decoder is such new product. It not only increases many new functions but also is more safety and reliable in use.

- Product Features**

- 1. High reliability:** this product is designed by adopting American PIC series single-chip microcomputer. It possesses many strong points such as ultra-strong anti-interference, anti-lock-up, low power consumption and strong driving capacity.
- 2. Communication interface:** possess RS-485 interfaces.
- 3. Baud rate setting:** Communication rate can be set as 2400baud, 4800 baud and 9600 baud.
- 4. Self-reading many protocols and manual set especial protocol:** Auto detect nearly 30 common PAN/TILT protocols such as SYYT, Pelco D, P, etc. and Identify especial protocols such as Manchester code, etc. through manual set DIP.
- 5. Time-limit protection function of cradle head and lens motors:** After executes cradle head and lens instructions, decoder does not receive corresponding stop instruction within limitative time (cradle head 60s, lens 10s), cradle head and lens output turn off automatically.

6. **Micro motion function (applicable to SYYT protocol):** cradle head and lens are very difficult to locate by conventional instruction in long focus state. However, this decoder sends micro motion instruction, execute micro motion operation and realize accurate location of cradle head and lens through control equipment.
7. Cradle head driving voltage 24VAC/220VAC are adjustable.
8. The 6VDC、12VDC lens' driving voltage is continuous and adjustable.
9. Provide output 12DC /500mA power supply for camera.
10. **485 load resistance:** jumper connects 120 jumper wires. Can switch on 120Ωload resistance.
- 11.**Wiper driver mode:** provide Alternating Current or switch mode driver wiper.

□ Schematic Diagram of Decoder Wiring and Description

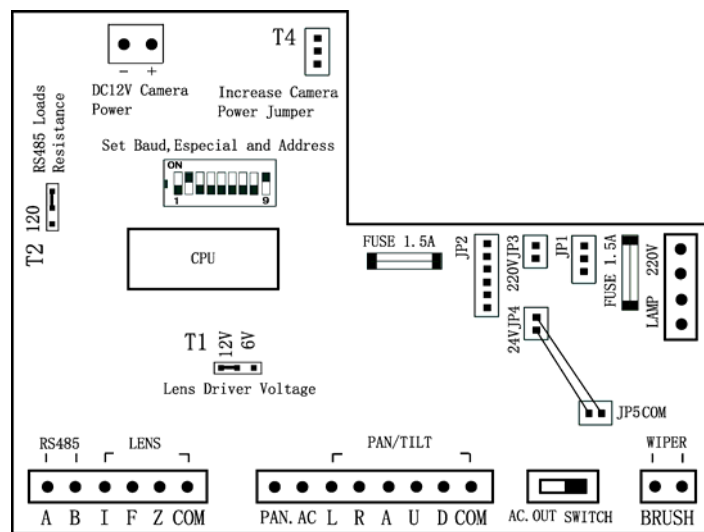

Diagram1

Table1

A.485 communication A	U.Tilt upwards output end(UP)
B.485 communication B	D.Tilt downwards output end(DOWN)
I. IRIS output (IRIS)	COM. Pan/Tilt public output end(COM)
F. Focus output (FOCUS)	BRUSH.WIPER output(AC or SWITCH)
Z. focal length output (ZOOM)	LAMP.LAMP output(AC 220V)
COM. Lens public output (COM)	220.AC 220V power supply
PAN.AC.AC voltage output(same as PAN/TILT Driver Voltage)	T1.Driving voltage of lens jumper wiring
L. Pan left output end(LEFT)	T2.RS-485 loads resistance jumper wiring
R. Pan right output end(RIGHT)	T4.Insease Camera power jumper
A. Pan automatic output end(AUTO)	12V.power of camera(DC 12V/400mA)

□ Choose the Driving Voltage of PAN/TILT

Provide 24VAC and 220VAC cradle head driving voltage. Set through JP3, JP4, JP5 a group of jumper wire, JP5 is the public end (conventional insert end), another end (set end) insert JP4, cradle head driving voltage is 24VAC; insert JP3, cradle head driving voltage is 220VAC. (jumper wire position is shown in figure 5)

When ex-factory, the set value of cradle head driving voltage is 24VAC.

Attention: prior to use, please confirm whether jumper wires are inserted in correct position

Adjust the Driving Voltage of Lens

The 6VDC、12VDC driving voltage of lens is continuous and adjustable. “T1” is the setting jumper wire. The numerical value that the jumper wire is opposite is the driving voltage of lens.

When ex-factory, the set value of lens driving voltage is 12VDC.

Set Communication Baud Rate and Special Protocol

The first to third position of red DIP dial switch is the set position of decoder communication baud rate and special protocol. The first position is high position, the second position is lower position.(Set ON=1,OFF=0)

Table2

DIP.1-3	Explain		Remark
000	Auto Detect protocol	2400bps	Look table3
001		4800bps	
010		9600bps	
011	-(reserve)	-	-
100	Lilin protocol	Especial protocol	Lilin keyboard
101	Kony protocol	Especial protocol	Kony system
110	EE protocol	Especial protocol	EE system
111	Manchester code	Especial protocol	AD、 AB、 WISH

The ex-factory set value is Self-reacting protocol .(9600 baud)

Self-reading Protocol Table

Talbe3

Protocol	Apply	Protocol	Apply	Protocol	Apply
SYYT	SYYT system	HN	HN system	HY	HY system
Pelco d and variation	Many system	ZR	CETC system	PWT	-
Pelco p and variation	Many system	Samsung	Many system	KRE-301	Kodicom 880
Vicon99	pico2000 system	SCC-641	Many system	JVC	JVC keyboard
Panasonic	Picaso system	YAAN	YAAN system	JY2000	-
HD600	shanghaiangfang	CCR-20G	Picaso system	Kalatel	Sony Vserver
RD140	CF system	CRR-1600	-	Wisdom	-
Pelco spectra	Pico2000 system	RM110	CF system		

Set Decoder Address

The fourth to the ninth position of red dial switch is the set position of decoder address. The fourth position is high position, the ninth position is lower position. The decoder address can be chosen from 1 to 63.

When the ninth position of DIP switch is ON, represent 1, When the eighth position of DIP switch is ON, represent 2, by analogy, When the fourth position of DIP switch is ON, represent 32.

DIP ADD \	4	5	6	7	8	9	DIP ADD \	4	5	6	7	8	9
1	0	0	0	0	0	1	33	1	0	0	0	0	1
2	0	0	0	0	1	0	34	1	0	0	0	1	0
3	0	0	0	0	1	1	35	1	0	0	0	1	1
4	0	0	0	1	0	0	36	1	0	0	1	0	0
5	0	0	0	1	0	1	37	1	0	0	1	0	1
6	0	0	0	1	1	0	38	1	0	0	1	1	0
7	0	0	0	1	1	1	39	1	0	0	1	1	1
8	0	0	1	0	0	0	40	1	0	1	0	0	0
9	0	0	1	0	0	1	41	1	0	1	0	0	1
10	0	0	1	0	1	0	42	1	0	1	0	1	0
11	0	0	1	0	1	1	43	1	0	1	0	1	1
12	0	0	1	1	0	0	44	1	0	1	1	0	0
13	0	0	1	1	0	1	45	1	0	1	1	0	1
14	0	0	1	1	1	0	46	1	0	1	1	1	0
15	0	0	1	1	1	1	47	1	0	1	1	1	1
16	0	1	0	0	0	0	48	1	1	0	0	0	0
17	0	1	0	0	0	1	49	1	1	0	0	0	1
18	0	1	0	0	1	0	50	1	1	0	0	1	0
19	0	1	0	0	1	1	51	1	1	0	0	1	1
20	0	1	0	1	0	0	52	1	1	0	1	0	0
21	0	1	0	1	0	1	53	1	1	0	1	0	1
22	0	1	0	1	1	0	54	1	1	0	1	1	0
23	0	1	0	1	1	1	55	1	1	0	1	1	1
24	0	1	1	0	0	0	56	1	1	1	0	0	0
25	0	1	1	0	0	1	57	1	1	1	0	0	1
26	0	1	1	0	1	0	58	1	1	1	0	1	0
27	0	1	1	0	1	1	59	1	1	1	0	1	1
28	0	1	1	1	0	0	60	1	1	1	1	0	0
29	0	1	1	1	0	1	61	1	1	1	1	0	1
30	0	1	1	1	1	0	62	1	1	1	1	1	0
31	0	1	1	1	1	1	63	1	1	1	1	1	1
32	1	0	0	0	0	0	note:0 is OFF, 1 is ON						

When ex-factory, corresponding address is 1.

Set Wiper Drive Mode

This decoder possesses two type of mode, Alternating Current or Switch mode. The switch that the circuit board has "AC.OUT SWITCH" is setting switch. Wiper driving mode is Alternating Current mode when the switch is on "AC.OUT" position, but it is Switch mode when the switch is on "SWITCH" position.

The ex-factory setting is SWITCH mode.

□ **Technical Parameters**

1. External power supply voltage: 220VAC±10%
2. Cradle head driving voltage: 220VAC(24VAC)±10%
3. Lens driving voltage: 6VDC、12VDC
4. 12VDC output voltage: 12VDC/500mA
5. Cradle head driving current:AC24V/500mA
6. Lens driving current: 100mA
7. Working temperature: indoor type -15□-70□

□ **Analysis and Solution of Common Faults**

Fault phenomenon	Fault analysis	Fault clearance
Decoder power turn-on, power supply pilot lamp does not light	<ol style="list-style-type: none"> 1. Have no 220V input 2. Fuse breaks 3. Looseness of transformer connection plug 	<ol style="list-style-type: none"> 1. Add 220V input 2. Replace fuse 3. Re-connect transformer plug
Control decoder has no response	<ol style="list-style-type: none"> 1. Wrong connection 2. Incorrect baud rate setting 3. Incorrect address setting 4. Incorrect 232/485 jumper wire 	<ol style="list-style-type: none"> 1. Correct connection 2. Set correct baud rate 3. Set correct address 4. Jumper connect correctly 232/485 jumper wire
Control decoder sometimes-response, sometimes no response	<ol style="list-style-type: none"> 1. Signal grounding is not well connected 2. The farthest end of 485 communication does not connect 120Ω load resistance 	<ol style="list-style-type: none"> 1. Well connect signal grounding 2. The farthest end jumper connects 120 jumper wire, switches on 120Ω load resistance
Short range control is normal , long distance control or meanwhile bringing many sets of decoders' work is abnormal	The driving capacity of 232/485 conversion equipment is not enough	Replace standard 232/485 conversion equipment (choose active)

